

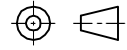

CABLE LENGTH	TOLERANCE*
ALL LENGTHS	+ 4% (OR 50mm) OF LENGTH - 0% (OR 0mm) OF LENGTH WHICHEVER IS GREATER
STRIP LENGTH	TOLERANCE*
0-7mm	±0.5mm
8-29mm	±1.0mm
30-49mm	±2.0mm
50-69mm	±3.0mm
70-100mm	±4.0mm
OVER 100mm	±5.0mm
* UNLESS OTHERWISE SPECIFIED	

- NOTES:
- "*" INDICATES CABLE LENGTH IN METERS. CONTACT TURCK TO ORDER SPECIFIC LENGTHS.
 - "/S90 DESIGNATES THERMOPLASTIC POLYURETHANE (TPU) CABLE.
 - "/S771" DESIGNATES BLACK MOLDED PLUG BODIES.

SOURCE DRAWING - FOR REFERENCE ONLY

RELATED DOCUMENTS 1. 2. 3. 4.	3RD ANGLE PROJECTION 	THIS DRAWING IS CONFIDENTIAL AND THE PROPERTY OF TURCK INC. USE OF THIS DOCUMENT WITHOUT WRITTEN PERMISSION IS PROHIBITED.	<div style="text-align: center;">  </div> 3000 CAMPUS DRIVE MINNEAPOLIS, MN 55441 1-800-544-7769 (763) 553-7300 (763) 553-0708 fax www.turck.us	DRFT RDS DATE 08/25/16 APVD L.H. SCALE 1=1.0 DESCRIPTION RKV 4T--*--PSG 3M/S90/S771	IDENTIFICATION NO. REV B
MATERIAL	ALL DIMENSIONS DISPLAYED ON THIS DRAWING ARE FOR REFERENCE ONLY	UNIT OF MEASUREMENT MILLIMETER [INCH]	DO NOT SCALE THIS DRAWING		
SEE SPECIFICATIONS		CONTACT TURCK FOR MORE INFORMATION			
FINISH	SEE SPECIFICATIONS	FILE: 777038117			

B	ADD COUPLING NUT TO P1 CONNECTOR, UPDATE DESCRIPT.	RDS	09/16/16	56730
REV	DESCRIPTION	BY	DATE	ECO NO.